

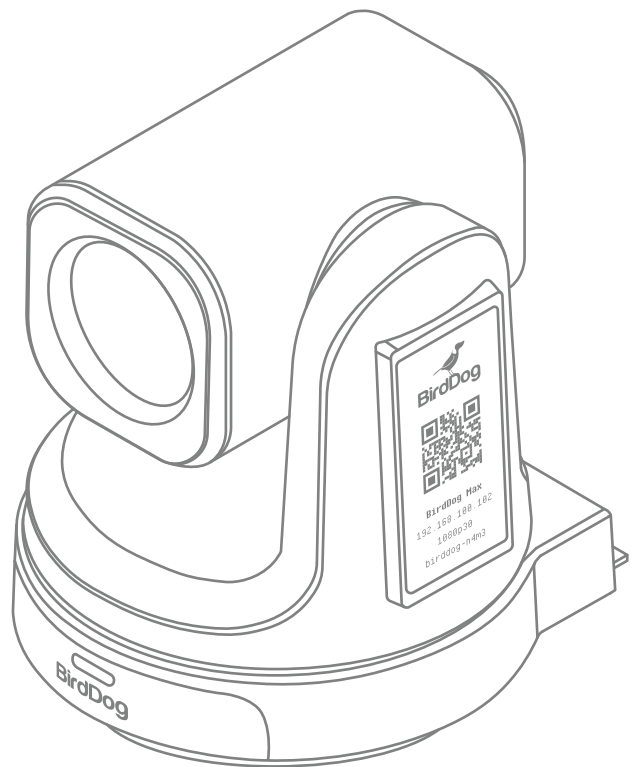

MAX

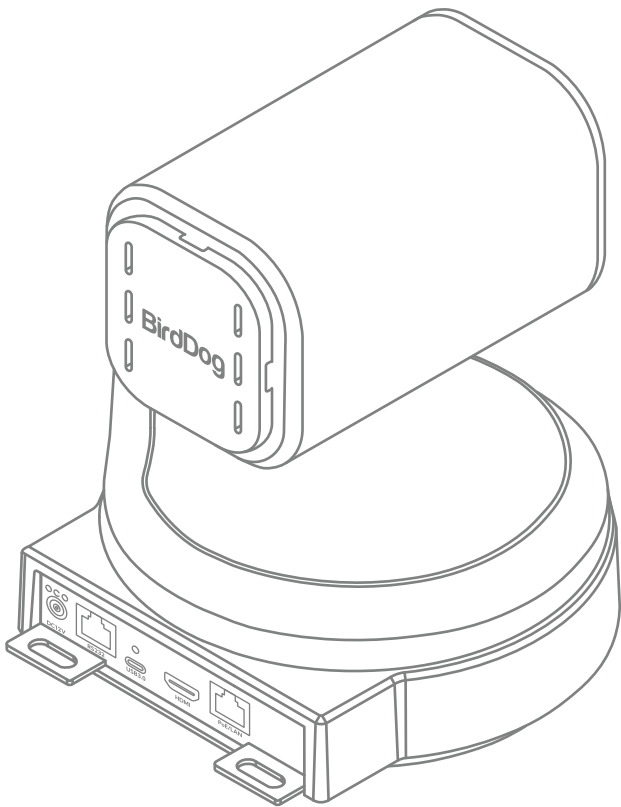

4K PTZ Camera

USER MANUAL

1 TABLE OF CONTENTS

Product description	2
What's in the box	3
Technical specifications	4
Remote control button description	5
Camera menu	6
Common operations	9
Installation instructions	11
Web configuration panel	12
Network setup	13
Camera dimensions	14
Warranty	15
Warning Information	16



NOTICE!

Specific frequencies of electromagnetic field may affect the image of the camera!

1 PRODUCT DESCRIPTION

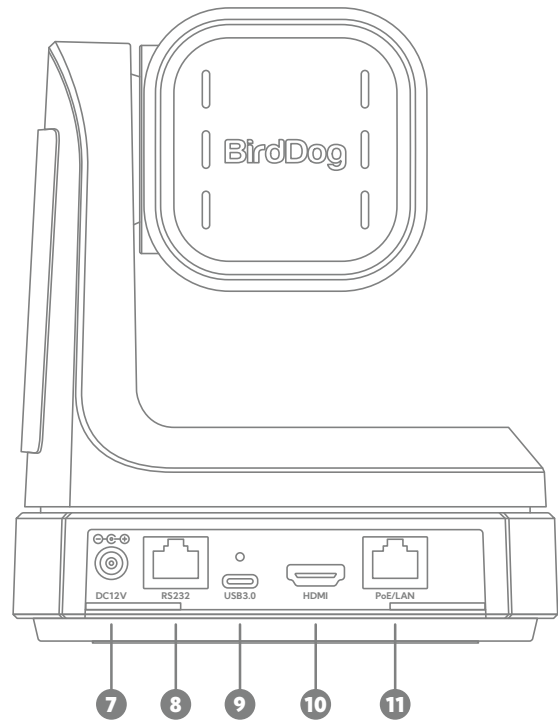
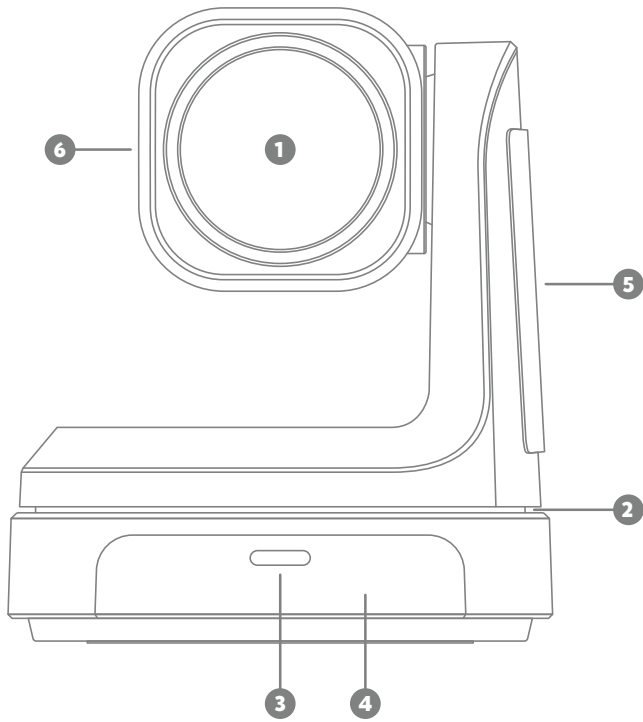

No.	Name
1	Lens
2	Pan & Tilt
3	Power & Standby indicator
4	IR Panel
5	Display (e-ink)
6	Tally Light

No.	Name
7	DC 12V
8	RS232
9	USB 3.0
10	HDMI
11	PoE/LAN

2 WHAT'S IN THE BOX



PTZ Camera



Remote Controller



DC 12V Power Supply



Welcome Pack

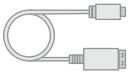

USB Cable

3 TECHNICAL SPECIFICATIONS

Feature	MAX
IMAGING	
Image Sensor	Sony 1/2.8" CMOS - ULTRA HD
Lens	f=3.42-40.02mm
Optical Zoom	12x
Video Format	HDMI: 2160p30/29.97/25, 1080p60/59.94/50/30/29.97/25, 720p60/59.94/50, NDI: 2160p30/29.97/25, 1080p30/29.97/25
Horizontal Angle of View	80.56(W)-7.89°(T)
Vertical Angle of View	49.61°(W)-4.46°(T)
Diagonal Angle of View	89.51°(W)-9.04°(T)
Aperture	F1.88-3.77
Focus	Auto, Manual
Exposure	Auto, Shutter Priority, Iris Priority, Manual
Backlight Compensation	Yes
Digital Noise Reduction	2D and 3D Noise Reduction
SNR	≥50dB
Effective Pixels	8.29 MP
MECHANICAL	
Pan/Tilt Rotation	±175°, -90° ~ +90°
Pan Control Speed	0.1 -80°/sec
Tilt Control Speed	0.1 -60°/sec
Preset Number	255 presets
I/O INTERFACE	
Video Output Interfaces	HDMI, USB-C UVC 1.1, Network
Video Compression Formats	H.264, H.265
Network Interfaces	100M adaptive Ethernet port; POE IEEE 802.3af
Encoder Network Protocols	NDI HX2, RTSP, RTMP
Control Interfaces	10M/100M Ethernet, RS232 (input & output), RS485, TYPE-C(UVC1.1)
Control Protocols	VISCA Baud Rate: 38400/9600/4800/2400, VISCA-IP, NDI
GENERAL	
Input Voltage	DC 12V, POE IEEE 802.3af
Input Current	2.0A (Max)
Power Consumption	13W (Max)
Working Temperature	0°C ~ +40°C
Working Humidity	20% ~ 80%
Dimension (W*H*D)	171.6*192.6*171.6mm/ 260*217*197mm (before / after packing)
Net & Gross Weight	1.43kg/2.096kg (Net/Gross weight)

4 REMOTE CONTROL

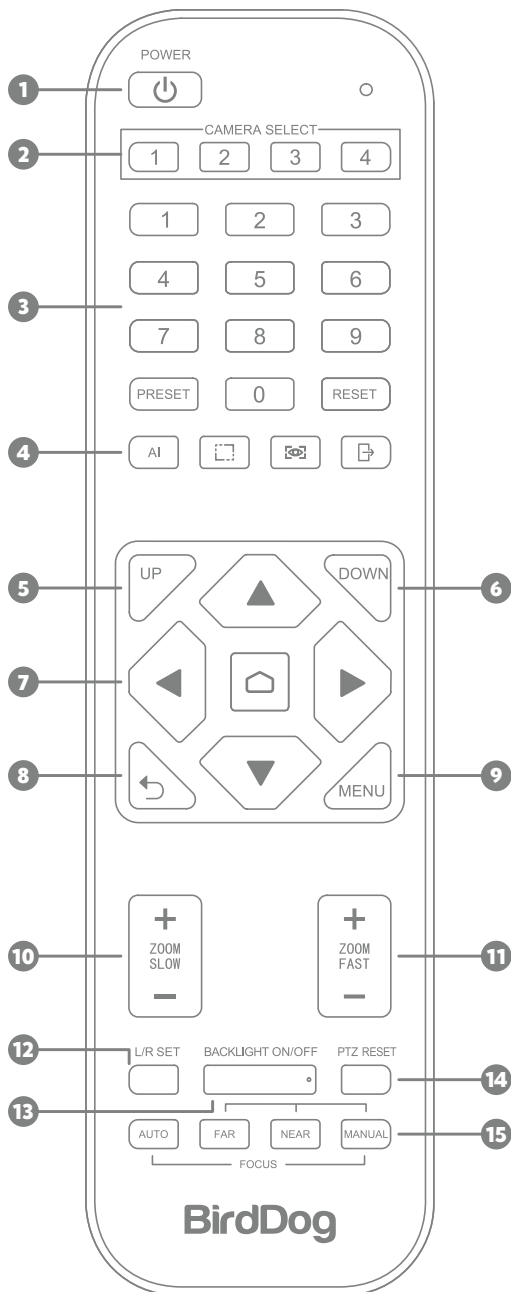

KEY DESCRIPTION

1. Standby/Power Key:

In standby, press to power on; After power on, press to enter standby.

2. CAMERA SELECT Keys

Press to control the camera.

3. Position

Preset position setup keys, include PRESET and RESET.

Set the preset position.

Reset the preset position.

4. AI Tracking

Auto-framing, auto-tracking, lock, exit.

5. UP

Flip image.

6. DOWN

Flip image.

7. PTZ Control Keys

PTZ move according to the arrow indicates.

Press  to move PTZ back to the middle position.

8. Return/EXIT

Return to previous menu or exit menu.

9. MENU

Enter or exit OSD Menu.

10. ZOOM Slow Key

Zoom in or out slowly.

11. ZOOM Fast Key

Zoom in or out quickly.

12. L/R Set

Horizontal control flip, press and hold for 10 sec.

13. BACKLIGHT Key

Turn on/off backlight compensation.

14. PTZ Reset

Re-calibrate PTZ.

15. FOCUS Keys

Auto/Far/Near/Manual.

5 CAMERA MENU

Press [MENU] on the remote control to enter main menu of the ptz camera.

5.1 Level 1 Menu - Main Menu

Main Menu	
→ Exposure	
Color	
Image	
Information	
Restore Default	
Language	English
[Home]	Enter
[Menu]	Back

Language: Support Chinese/English.
Click the Home button on the Remote to enter level 2 sub-menu.
Click the Menu button on the Remote to exit menu.

5.2 Level 2, Menu - Exposure

Exposure	
→ Mode	Auto
Backlight	On/Off
ExpComp	0-15
Flicker	50/60Hz
[Return]	

Mode: Auto/Manual
Backlight Comp. : You can turn On/Off the backlight. When the background of the subject is too bright, or when the subject is too dark, backlight comp. will make the subject appear clearer.
Exp. Comp. (exposure compensation): When mode is set to Auto, set this item to ON to enable exp. comp. When you set it to ON, you can select the exp. comp. level from 0 to 15.
Flicker: Support 50Hz/60Hz.
When changing the exposure mode to Manual, the sub-menu is the following

Exposure	
→ Mode	Manual
Iris	F1.6
Shutter	1/100000~1/25
Gain	50
Flicker	50Hz/60Hz
[Return]	

Iris: F No. Setting, the value should be F1.6/F2.0/F2.4/F2.8/F3.4/F4.0/F4.8/F5.6/F6.8/F8.0/F9.6

Shutter: Shutter value setting, the value is between 1/100000 and 1 Gain, exposure gain setting, optional item is 0 to 99

5.3 Level 2 Menu-Color

Color	
→ Brightness	50
Contrast	50
Hue	50
Saturation	50
Sharpness	50
WB Mode	Auto
Rtuning	50
Btuning	50
[Return]	

Brightness: Set image brightness Dynamically. Default 50, optional item 0-99
Contrast: Set image contrast Dynamically. Default 50, optional item 0-99
Hue: Set the relative brightness of the image. Default 50, optional item 0-99
Saturation: Set image color effect. Default 50, optional item 0-99
Sharpness: Set sharpness level. Default 50, optional item 0-99
WB mode: Auto/Manual/VAR
When the WB mode is Auto, the R-tuning and B-tuning value can be tuning, the range is 0 to 99;

When the WB mode is Manual, the sub menu will be the following:

Color	
→ Brightness	50
Contrast	50
Hue	50
Saturation	50
Sharpness	50
WB Mode	Manual
Rtuning	50
Btuning	50
Rgain	50
Bgain	50
[Return]	

In manual WB mode, the followings value can be adjusted. The Rgain and Bgain value can be turned, the range is 0 to 99;

When the WB mode is VAR, the sub menu will be the following:

Color	
→ Brightness	50
Contrast	50
Hue	50
Saturation	50
Sharpness	50
WB Mode	VAR
Color Temp	2500K~9000K
Rtuning	50
Btuning	50
[Return]	

The range for the color temp can be adjusted between 2500K to 9000K.

5.4 Level 2 Menu Image

Image	
→ Flip	Off/On
Mirror	Off/On
Video Format	1090P60
USB Mode	ISOC/BULK
Style	Normal/PC/Bright
[Return]	

Flip: Enable/disable the picture up/down flip

Mirror: Enable/disable the picture left/right flip

Video Format: 1080P60/1080P50/1080P30/1080P25/720P/60/720P/50

USB Mode: ISOC/BULK

USB mode: Adjust between Isochronous transfers mode and Bulk transfers mode

Style Mode: Normal, PC, Bright

5.5 Level 2 Menu-Information

Information	
Model	MAX
Version	1.1.1.1 2025-01-01
→ [Return]	

Model: MAX

Version: 1.1.1.1

Date: 2025-01-01

Notice: The version number here is just an example, the actual parameters shall prevail.

Restore Default	
Restore?	No/Yes
→ [Return]	

When the WB mode is Manual, the sub menu will be the following:

Communication	
→ Protocol	Pelco-D
Address	1~255
Baudrate	9600
RC Address	All/1/2/3/4
[Return]	

Communication	
→ Protocol	Pelco-P
Address	1~32
Baudrate	9600
RC Address	All/1/2/3/4
[Return]	

Protocol: Auto/Visca/Pelco-D/Pelco-P

Baudrate: 2400/4800/9600/38400

RC Address: All/1/2/3/4

5.6 Level 2 Menu-Information

Information	
Model	MAX
Version	1.1.1.1 2025-01-01
→ [Return]	

Model: MAX

Version: 1.1.1.0

Date: 2025-01-01

Notice: The version number here is just an example, the actual version will be shown.

Restore Default	
Restore?	No/Yes
→ [Return]	

6 COMMON OPERATIONS

6.1 Camera Select



Select IR Remote camera operation from ALL to a specific number in the Communications setting in the OSD menu.

6.2 Camera Direction Control

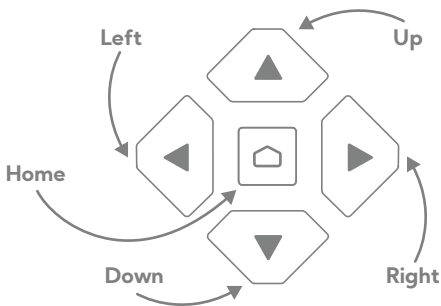

6.3 Camera Focusing Mode Control



[AUTO FOCUS]

Switch the focus mode to AUTO

[MANUAL FOCUS]

Switch the focus mode to MANUAL

[FAR] Far focus manually

[NEAR] Near focus manually

6.4 Camera Zoom Control



Press any one of the 4 [ZOOM] to make the zoom functioning.

6.5 Preset Setup, Call, Cancel



Save Preset: Press [PRESET], then press one of the numbers (0- 9) to reserve a preset that correspond to the NUMBER.

Note: You can setup 10 presets at most by the remote control.

Call Preset: Press the NUMBER (0-9) directly to call the reserved preset. Note: Itwon't work ifthere's no preset reserved in the correspond-ed number.

Remove Preset: Press [RESET], then press one of the number (0-9) to remove a preset that corresponds to the NUMBER.

6.6 Using RS-232 (VISCA)

You can use the RS-232 port to connect to optional controllers, such as a joystick control keyboard, or control PC station, to operate the camera, perform pan, tilt and zoom operations and to use the Preset function using the control buttons.

An application software that supports this unit is needed if you use a PC station.

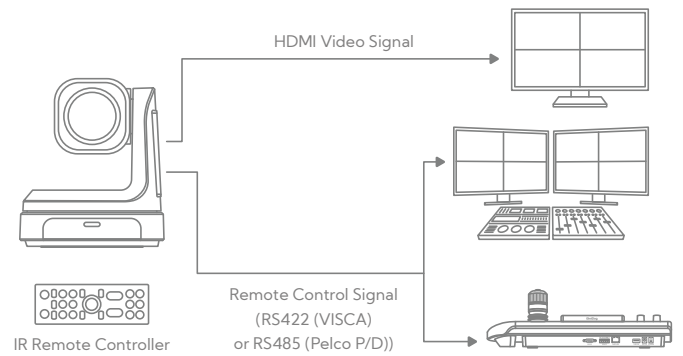

RS232 Connection:

- In order to use a RJ45 to RS232 (VISCA) cable, the controller must be VISCA compatible.
- You can use CAT5/6 cable (T-568B standard pinout) to make an RS232 connection by following the pin definition shown here.
- You can use RS232 to daisy chain multiple camera connection with a standard RS232 serial port controller using the configuration shown here.

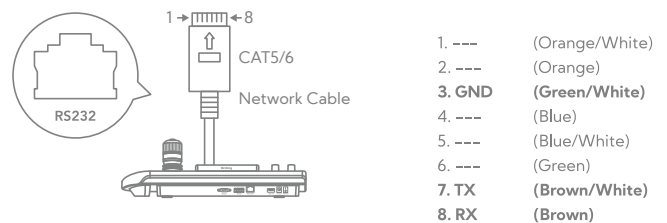

RS232 Serial port connection on controller side.

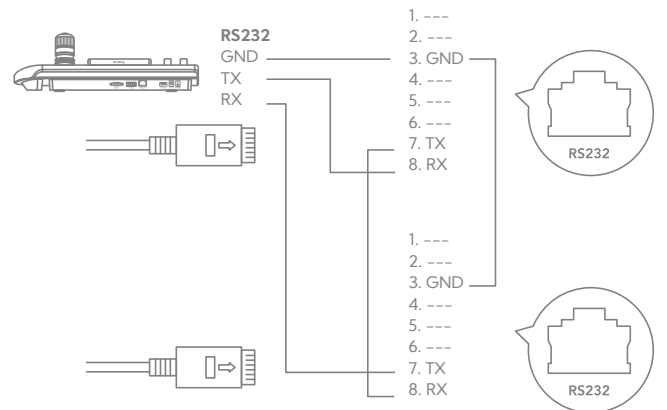

7 INSTALLATION INSTRUCTIONS

7.1 Surface Installation

Put the camera on a level surface, and make sure the camera is in a horizontal position. If you want to put the camera on a non-level surface, please make sure the mounting angle of the camera base is less than 15 degrees to ensure the camera pan and tilt work normally.

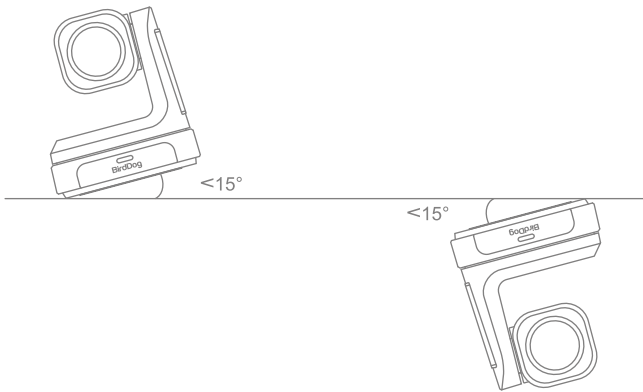

7.2 Wall Mount Installation

Step 1: Mounting the wall mount bracket

Wall mount bracket
(This side is to the wall.)



Mounting the bracket vertically to the wall with screws.

Step 2: Install the camera

Screw hole

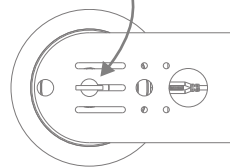

Rotate the camera clockwise to install it.

8 WEB CONFIGURATION PANEL

BirdDog cameras have a web interface (also known as BirdUI) that is displayed by your computer browser and can be used to configure your camera remotely.

In order to access to the dedicated panel, you will need to scan the QR Code present on your camera e-ink screen, or via web browser by inserting the correct address IP as a web link.

An alternative way is through NDI Studio Monitor application:

1. Click on the gear icon on the bottom right of the Studio Monitor window.
2. In the displayed window, type the default password 'birddog' (all lower case) and click the OK button. The dashboard window is displayed.

The dashboard shows important basic camera settings. For now, check that the displayed Status is Active and take note of the frame rate that is currently output from the camera (displayed under NDI® connection info). This frame rate should be set identically for all cameras according to the requirements of your production.



Note:

For more information about the BirdUI, please visit BirdDog.tv/downloads, or, BirdDog.tv/birdui-overview

BirdDog Camera MAX Device Mode: Encoding
Source Status: Streaming NDI

75% **System Utilization**

Device Mode: **Encoding**
Source Status: **Streaming NDI**

50% **Network Bandwidth**

Status
 NDI Video Stream Name: **CAM** Video Format: **1080p60** Streaming Protocol: **NDI HX**

Stream Info
 Video Resolution: **1920x1080** Video Frame Rate: **59.94** Video Sample Rate: **4:2:2**
 Genlock Status: **Not Active** Network Mode: **RUDP** Average Bitrate: **134Mbps**

System Details
 System Name: **birddog-max** Eth. IP Address: **192.168.100.100** Firmware Version: **BirdDog_MAX1.0.2**
 Status: **Active** MAC Address: **a2:4e:ff:63:6b:22** Network Config Method: **DHCP**

Device Restart

System Reboot

BirdDog.tv

9 NETWORK SETUP

BirdDog PTZ MAX Device Mode: Encode
Source Status: Streaming NDI

Ethernet Network

Configuration Method	<input type="radio"/> STATIC <input type="radio"/> DHCP	DHCP Timeout	<input type="text" value="20s"/>
IP Address	<input type="text" value="192.168.100.100"/>	DHCP Fallback IP Address	<input type="text" value="192.168.100.100"/>
Subnet Mask	<input type="text" value="255.255.255.0"/>	SHCP Fallback Sub. Mask	<input type="text" value="255.255.255.0"/>
Gateway Address	<input type="text" value="192.168.100.1"/>	BirdDog Name	<input type="text" value="BirdDog-MAX.local"/>

9.1 Ethernet Network Configuration

Most computer networks provide for both automatic and manual configuration of network devices and MAX can accommodate both.

Static or DHCP

Here you can set the network configuration to either DHCP (default) or Static. DHCP simplifies the management of IP addresses on networks. No two hosts can have the same IP address, so assigning them manually can potentially lead to errors. If your network is set up for DHCP, this is generally the best configuration to choose.

If you do choose to go with a Static IP address, you'll need to add the IP Address, Subnet Mask and Gateway Address information according to the requirements of your network.

DHCP Timeout, Fallback IP address, Fallback Subnet Mask

You can set the timeout period during which MAX will look for a DHCP IP address. After this period, the camera will default to the designated fallback IP address.

This can be useful if you use your camera in

other network environments. For example, if a DHCP server is available in your normal office or studio application, the camera will use the DHCP supplied IP address. If you then use the camera in another application without a DHCP server, your camera will always default to the known fallback IP address.

BirdDog Name

You can give your camera a meaningful name to make identification easier when viewing NDI® sources on a receiver such as a TriCaster, vMix or Studio Monitor. Be sure to make the name unique, as no two devices on the network should have the same name. The name can be any combination of 'a-z, 0-9, and -'.

After renaming your camera, navigate back to the Dashboard and click REBOOT DEVICE. The camera will re-initialize and you'll be good to go.

Note:

Your computer will need to have 'Bonjour' services loaded in order to access the unit via its user defined name. Apple devices come pre-installed with Bonjour, while Windows devices need a plugin.

10 CAMERA DIMENSIONS

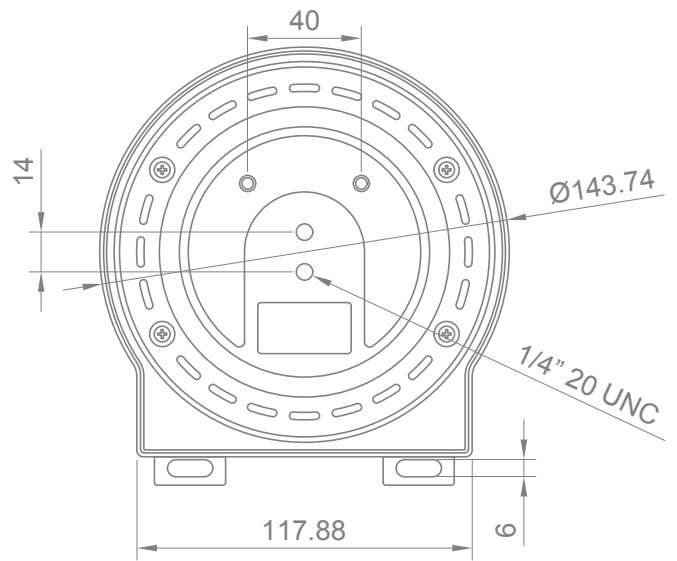
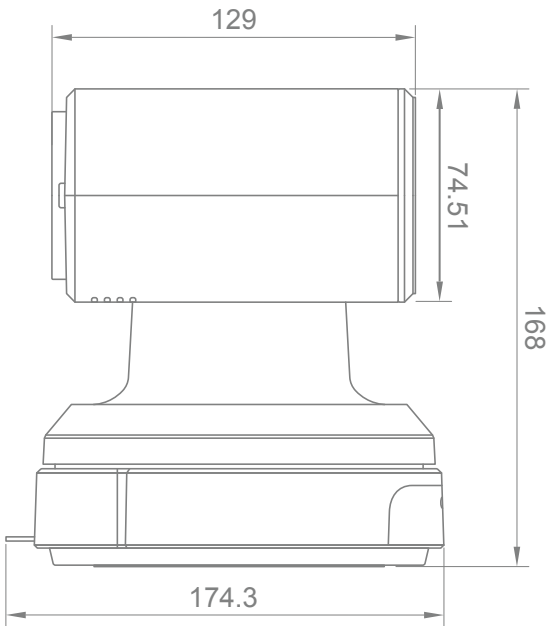
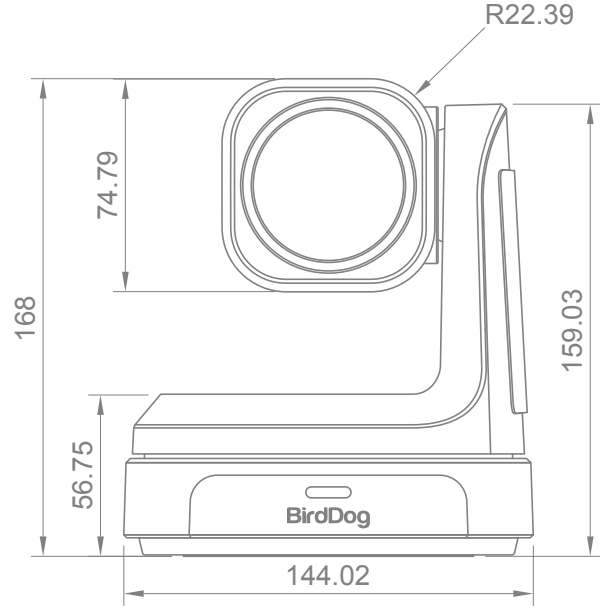
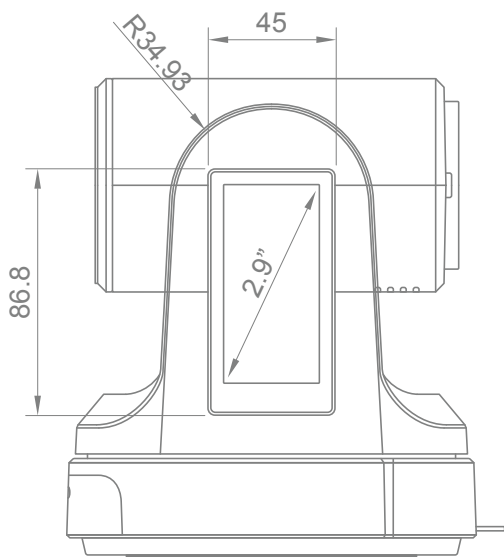

11 WARRANTY

5 Year Warranty

BirdDog P-series and X-series cameras feature a 5 year, global warranty. BirdDog prides itself on delivering the best possible products to customers, but if something was to go wrong, you can rest assured knowing that no matter where in the world you are, BirdDog has your back.

Read more at BirdDog.tv/warranty-terms

FCC regulatory conformance

This device complies with Part 15 of the FCC Rules. Operation is subject to the following two conditions:

- (1) This device may not cause harmful interference.
- (2) This device must accept any interference received, including interference that may cause undesired operation.

NOTE: This equipment has been tested and found to comply with the limits for a **Class B** digital device, pursuant to part 15 of the FCC Rules. These limits are designed to provide reasonable protection against harmful interference in a residential installation. This equipment generates uses and can radiate radio frequency energy and, if not installed and used in accordance with the instructions, may cause harmful interference to radio communications. However, there is no guarantee that interference will not occur in a particular installation. If this equipment does cause harmful interference to radio or television reception, which can be determined by turning the equipment off and on, the user is encouraged to try to correct the interference by one or more of the following measures:

- Reorient or relocate the receiving antenna.
- Increase the separation between the equipment and receiver.
- Connect the equipment into an outlet on a circuit different from that to which the receiver is connected.
- Consult the dealer or an experienced radio/TV technician for help.

NOTE: The manufacturer is not responsible for any radio or TV interference caused by unauthorized modifications to this equipment. Such modifications could void the user's authority to operate the equipment.

RF Exposure

This equipment complies with FCC radiation exposure limits set forth for an uncontrolled environment. This equipment should be installed and operated with minimum distance of 20 cm between the radiator and your body. This transmitter must not be co-located or operating in conjunction with any other antenna or transmitter.

IC regulatory conformance

This device complies with CAN ICES-003 (B)/NMB-003(B).

This device complies with Industry Canada licence-exempt RSS standard(s). Operation is subject to the following two conditions:

- (1) this device may not cause harmful interference, and
- (2) this device must accept any interference received, including interference that may cause undesired operation.

Cet appareil est conforme à la norme CAN ICES-003 (B)/NMB-003 (B).

Le présent appareil est conforme aux CNR d'Industrie Canada applicables aux appareils radio exempts de licence. L'exploitation est autorisée aux deux conditions suivantes :

- (1) l'appareil ne doit pas produire de brouillage, et
- (2) l'utilisateur de l'appareil doit accepter tout brouillage radioélectrique subi, même si le brouillage est susceptible d'en compromettre le fonctionnement.

RF Exposure

This equipment complies with FCC radiation exposure limits set forth for an uncontrolled environment. This equipment should be installed and operated with minimum distance of 20 cm between the radiator and your body. This transmitter must not be co-located or operating in conjunction with any other antenna or transmitter.

Cet équipement est conforme aux limites d'exposition aux rayonnements de la IC établies pour un environnement non contrôlé. Cet équipement doit être installé et fonctionner à au moins 20cm de distance d'un radiateur ou de votre corps.

EU regulatory conformance

RF exposure information: The Maximum Permissible Exposure (MPE) level has been calculated based on a distance of 20cm between the device and the human body. To maintain compliance with RF exposure requirement, use product that maintain a 20cm distance between the device and human body.

CE DOC

Hereby, BirdDog Australia declares that the radio equipment type MAX is in compliance with Directive 2014/53/EU. The full text of the EU declaration of conformity is available at the following internet address: birddog.tv/compliance

Manufacturer information:

Company name: BirdDog Technology Ltd
1-9 Sackville Street, Level4, Collingwood, VIC, 3066, Australia

Operation temperature: 0~55° C
Operation frequency (Max power)
Bluetooth: 2402~2480 (9dBm)



BirdDog

BirdDog.tv